

Ra = Radius all wheels steered
 Radius allradgelenkt
 Rayon toutes les roues directrices
 Radio de giro con todas las ruedas giradas
 Raggio di curva con tutte le ruote sterzate

14



12,9 – 60,0 m



11/18/
26/32 m



7,5 m



360°

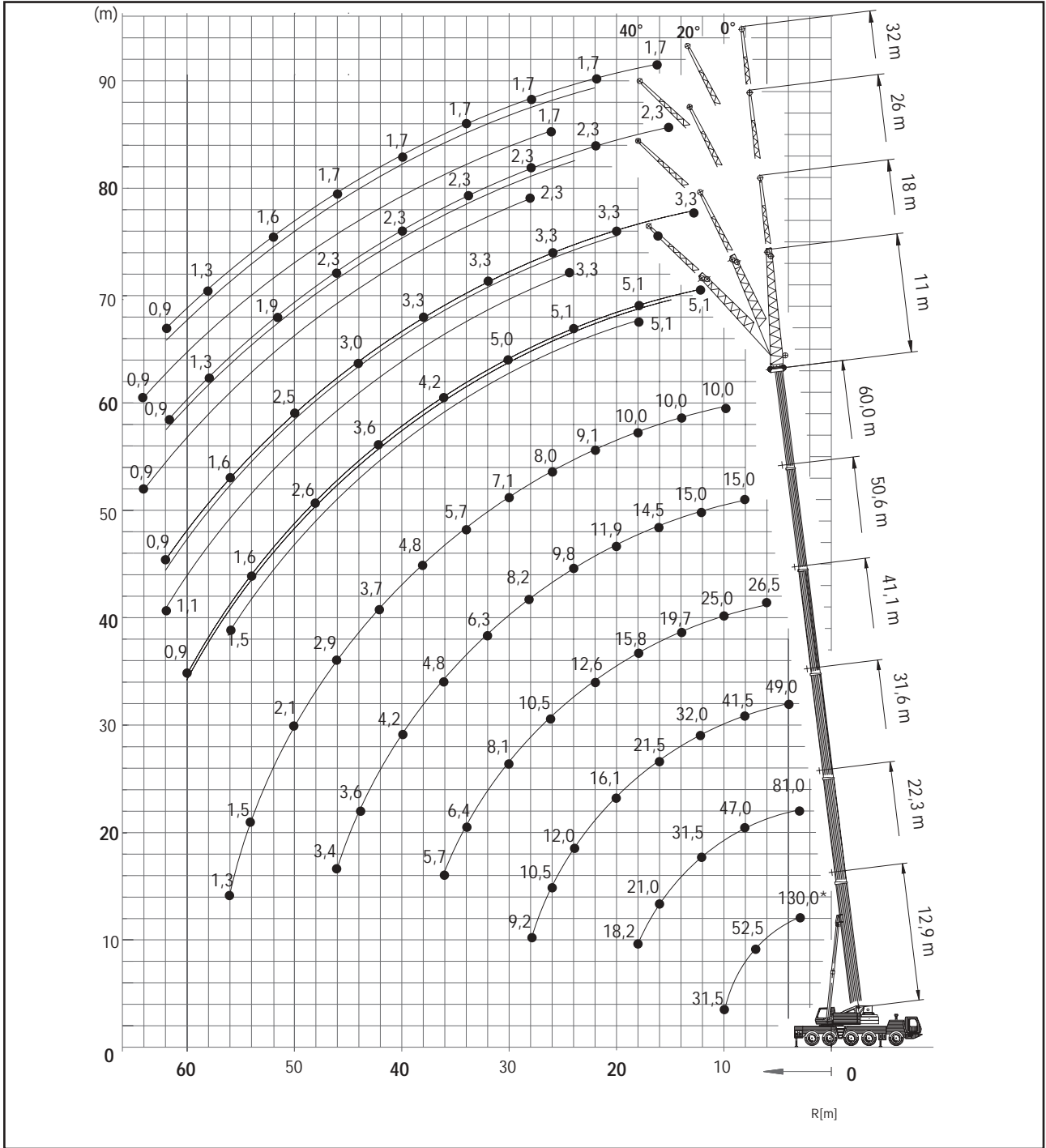

GMK5130-1

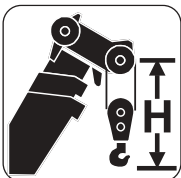

Hook block • Unterflasche • Crochet-moufle • Gancho • Ganci
(t)

120 D

H
(mm)

100 D

3160

75 D

3070

50 E

3000

20 E

2770

8 H/B

2350

Load charts • Traglasten • Capacités de levage • Capacidades • Capacità

Telescopic boom • Teleskopausleger • Flèche principale • Pluma telescópica • Braccio telescopico



12,9 – 60 m



7,5 m



360°



40,1 t



DIN/ISO

m	12,9*	12,9	17,6	22,3	27,0	31,6	36,3	41,1	45,8	50,6	55,3	60,0
2,5	130°/110,0											
3,0	94,5	93,5	86,0	81,0	61,0							
4,0	81,0	78,5	76,5	71,0	61,0	49,0						
5,0	70,5	68,0	67,5	63,5	60,5	49,0	36,5					
6,0	62,0	59,0	59,5	57,5	54,5	47,0	36,5	26,5				
7,0	54,5	52,5	53,0	52,0	50,0	44,0	35,0	26,5	20,0			
8,0	48,0	46,5	47,0	47,0	46,0	41,5	33,0	26,5	20,0	15,0		
9,0	41,0	41,0	42,0	42,0	41,5	39,0	31,5	26,5	20,0	15,0	11,5	
10,0	31,5	31,5	38,0	38,0	37,5	37,0	29,5	25,0	20,0	15,0	11,5	10,0
11,0			34,5	34,5	34,0	34,5	28,0	23,5	20,0	15,0	11,5	10,0
12,0			31,5	31,5	31,0	32,0	26,5	22,5	19,5	15,0	11,5	10,0
13,0			29,0	29,0	28,5	29,5	25,0	21,0	18,6	15,0	11,5	10,0
14,0			24,5	26,0	26,0	26,5	23,5	19,7	17,7	15,0	11,5	10,0
15,0				23,5	24,5	24,0	22,5	18,7	16,8	15,0	11,5	10,0
16,0				21,0	22,0	21,5	21,5	17,6	15,9	14,5	11,5	10,0
18,0				18,2	18,2	17,6	18,4	15,8	14,4	13,0	11,5	10,0
20,0					15,3	16,1	15,5	13,9	12,7	11,9	11,1	9,7
22,0					13,0	13,8	13,3	12,6	11,5	10,8	10,3	9,1
24,0					9,5	12,0	11,4	11,6	10,4	9,8	9,4	8,6
26,0						10,5	9,9	10,5	9,4	8,9	8,6	8,0
28,0						9,2	9,3	9,2	8,1	8,2	7,9	7,6
30,0							8,7	8,1	7,5	7,2	7,3	7,1
32,0							7,7	7,2	6,9	6,3	6,5	6,4
34,0								6,4	6,2	5,5	5,7	5,7
36,0								5,7	5,9	4,8	5,3	5,3
38,0									5,3	4,5	5,0	4,8
40,0									4,7	4,2	4,6	4,2
42,0									4,2	3,9	4,1	3,7
44,0										3,6	3,7	3,3
46,0										3,4	3,3	2,9
48,0											2,9	2,5
50,0											2,5	2,1
52,0												1,8
54,0												1,5
56,0												1,3



12,9 – 60 m



7,5 m



360°



23,5 t





DIN/ISO

m	12,9*	12,9	17,6	22,3	27,0	31,6	36,3	41,1	45,8	50,6	55,3	60,0
2,5	130°/110,0											
3,0	94,5	91,5	86,0	81,0	61,0							
4,0	81,0	77,0	76,5	71,0	61,0	49,0						
5,0	70,5	66,5	66,5	63,5	60,5	49,0	36,5					
6,0	62,0	57,5	58,0	57,0	54,5	47,0	36,5	26,5				
7,0	54,5	50,0	50,5	50,5	48,5	44,0	35,0	26,5	20,0			
8,0	47,5	44,5	45,0	44,0	40,5	39,5	33,0	26,5	20,0	15,0		
9,0	39,0	38,5	39,0	37,5	36,5	34,0	31,5	26,5	20,0	15,0	11,5	
10,0	31,5	31,5	33,5	32,5	31,5	29,5	29,0	25,0	20,0	15,0	11,5	10,0
11,0			28,5	28,0	28,0	26,0	26,0	23,5	20,0	15,0	11,5	10,0
12,0			24,5	25,0	25,0	24,5	23,0	21,5	19,5	15,0	11,5	10,0
13,0			22,0	22,0	22,0	22,5	20,5	19,3	18,6	15,0	11,5	10,0
14,0			19,5	19,5	19,2	20,0	18,7	17,5	16,8	15,0	11,5	10,0
15,0				17,4	18,0	18,0	17,0	16,7	15,2	14,9	11,5	10,0
16,0				16,4	16,5	16,2	15,5	15,7	13,9	13,6	11,5	10,0
18,0				13,4	13,6	13,2	13,3	13,3	11,6	11,4	11,5	10,0
20,0					11,3	11,0	11,7	11,1	10,7	9,6	9,7	9,7
22,0					9,6	9,3	9,9	9,3	9,7	8,5	8,9	8,5
24,0					5,9	7,9	8,4	7,9	8,2	7,8	8,0	7,3
26,0						6,7	7,3	6,7	7,1	7,3	7,0	6,3
28,0						5,7	6,3	5,8	6,1	6,3	6,0	5,5
30,0							5,6	4,9	5,4	5,5	5,1	4,7
32,0							5,2	4,5	5,0	4,8	4,4	4,0
34,0								4,2	4,4	4,1	3,8	3,4
36,0								3,9	3,8	3,6	3,2	2,8
38,0									3,3	3,1	2,7	2,3
40,0									2,9	2,6	2,3	1,9
42,0									2,5	2,2	1,9	1,5
44,0										1,9	1,6	1,2
46,0										1,6	1,3	
48,0											1,0	

** Over rear with special equipment. Nach hinten mit Sonderausrüstung. En arrière avec équipement spécial. Por la parte trasera con equipo especial. Soil'antérieure con equipaggiamento speciale.

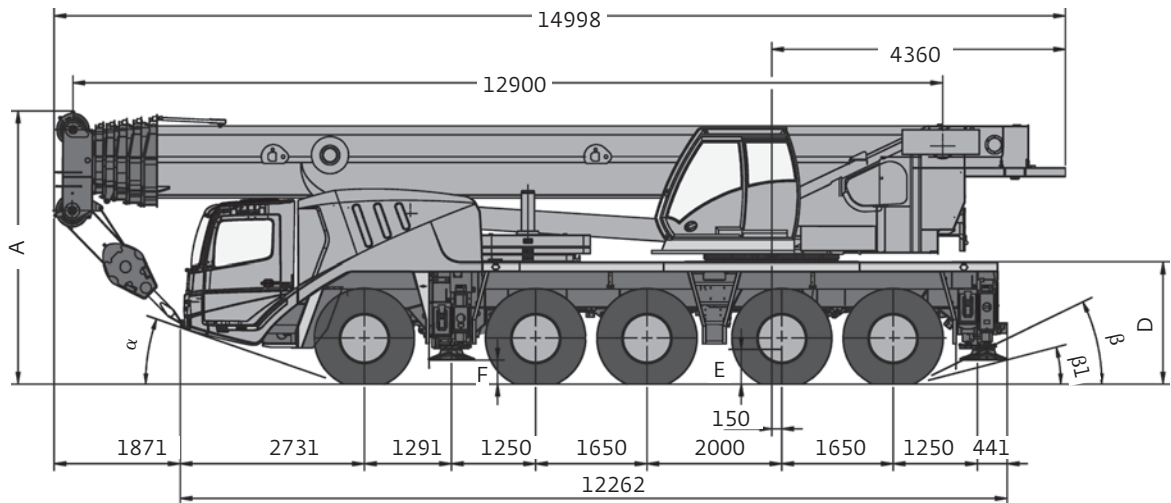
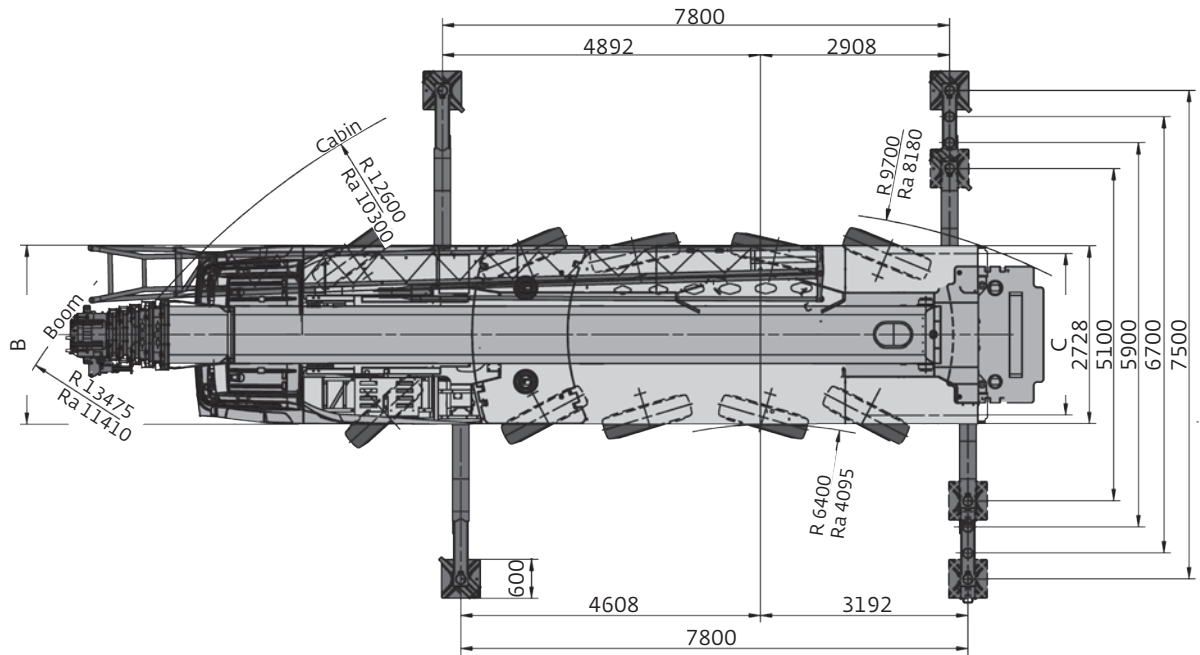
Dimensions • Abmessungen • Encombrement
Dimensiones • Dimensioni • Размеры



	A	A 130 mm*	B	C	D	E	F	α	β	β1
14.00 R25	3945	3815	2750	2338	1750	435	356	18	23	17
16.00 R25	3995	3865	3000	2486	1800	485	386	20	25	19
20.5 R25	3995	3865	3000	2507	1800	485	386	20	25	19

* Lowered • Abgesenkt • Surbaissée • Abbassato • Rebaja • Сниженный

Ra = Radius all wheels steered • Radius allradgelenkt • Rayon toutes les roues directrices
 Radio de giro con todas las ruedas giradas • Raggio di curva con tutte le ruote sterzate
 Радиус поворота при управлении всеми колесами

Load charts • Traglasten • Capacités de levage Capacidades • Capacità • Таблицы грузоподъемности

Working range • Arbeitsbereiche • Diagramme de levage • Gama de trabajo • Area di lavoro • Грузовысотные характеристики

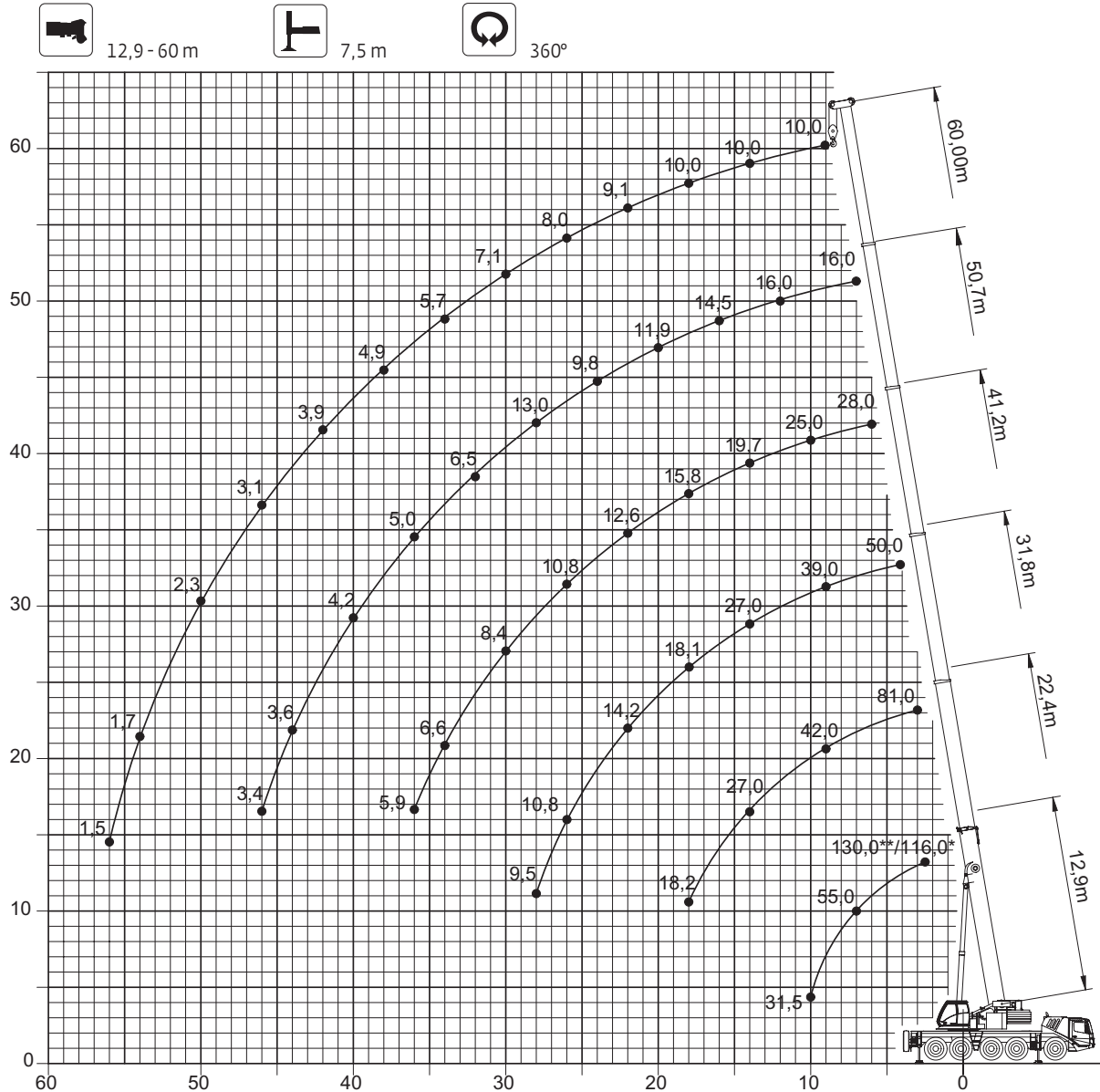

* 0° over rear • nach hinten • en arrière • por la parte trasera • sul posteriore • Над задней частью

** 0° over rear with special equipment • Nach hinten mit Zusatzeinrichtung • En arrière avec équipement supplémentaires • Por la parte trasera con equipo adicional, sull'anteriore con equipaggiamento ausiliario • Над задней частью с специальным оборудованием

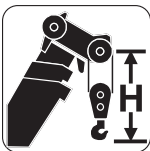
	Hook block • Unterflasche • Crochet-moufle Gancho • Ganci • Крюковой блок (t)	H (mm)
		120 D
	100 D	3160
	75 D	3070
	50 E	3000
	20 E	2770
	8 H/B	2350

Load charts • Traglasten • Capacités de levage Capacidades • Capacità • Таблицы грузоподъемности

Telescopic boom • Teleskopausleger • Flèche principale • Pluma telescópica • Braccio telescopico • Телескопическая стрела



12,9 - 60 m



7,5 m



360°



40,1 t



EN 13000

m	12,90°	12,90	17,69	22,48	27,16	31,84	36,45	41,24	45,99	50,71	55,39	60,00	m
2,2	130,0°/116,0°	-	-	-	-	-	-	-	-	-	-	-	2,2
3,0	94,5	93,5	86,0	81,0	65,0	-	-	-	-	-	-	-	3,0
4,0	81,0	79,0	76,5	71,0	65,0	50,0	-	-	-	-	-	-	4,0
5,0	70,5	68,0	67,5	63,5	60,5	49,5	38,0	-	-	-	-	-	5,0
6,0	62,0	59,5	60,0	57,5	54,5	47,0	37,0	28,0	20,5	-	-	-	6,0
7,0	55,0	52,5	53,0	52,0	50,0	44,0	35,0	28,0	20,5	16,0	-	-	7,0
8,0	48,0	46,5	47,0	47,0	46,0	41,5	33,0	28,0	20,5	16,0	11,6	-	8,0
9,0	41,0	41,0	42,0	42,0	41,5	39,0	31,5	26,5	20,5	16,0	11,6	10,0	9,0
10,0	31,5	31,5	38,0	38,0	37,5	37,0	29,5	25,0	20,5	16,0	11,6	10,0	10,0
11,0	-	-	34,5	34,5	34,0	34,5	28,0	23,5	20,5	16,0	11,6	10,0	11,0
12,0	-	-	31,5	31,5	31,0	32,0	26,5	22,5	19,5	16,0	11,6	10,0	12,0
13,0	-	-	29,0	29,0	28,5	29,5	25,0	21,0	18,6	16,0	11,6	10,0	13,0
14,0	-	-	25,0	27,0	26,0	27,0	23,5	19,7	17,7	15,8	11,6	10,0	14,0
15,0	-	-	-	24,0	24,5	24,5	22,5	18,7	16,8	15,2	11,6	10,0	15,0
16,0	-	-	-	21,5	22,5	22,0	21,5	17,6	15,9	14,5	11,6	10,0	16,0
18,0	-	-	-	18,2	18,6	18,1	18,9	15,8	14,4	13,0	11,6	10,0	18,0
20,0	-	-	-	-	15,7	16,1	15,9	13,9	12,7	11,9	11,1	9,7	20,0
22,0	-	-	-	-	13,4	14,2	13,6	12,6	11,5	10,8	10,3	9,1	22,0
24,0	-	-	-	-	9,6	12,3	11,8	11,6	10,4	9,8	9,4	8,6	24,0
26,0	-	-	-	-	-	10,8	10,2	10,8	9,5	8,9	8,6	8,0	26,0
28,0	-	-	-	-	-	9,5	9,3	9,5	8,4	8,2	7,9	7,6	28,0
30,0	-	-	-	-	-	-	8,7	8,4	7,5	7,5	7,3	7,1	30,0
32,0	-	-	-	-	-	-	8,0	7,5	6,9	6,5	6,5	6,4	32,0
34,0	-	-	-	-	-	-	-	6,6	6,2	5,7	5,7	5,7	34,0
36,0	-	-	-	-	-	-	-	5,9	5,9	5,0	5,3	5,3	36,0
38,0	-	-	-	-	-	-	-	-	5,5	4,5	5,0	4,9	38,0
40,0	-	-	-	-	-	-	-	-	5,0	4,2	4,7	4,5	40,0
42,0	-	-	-	-	-	-	-	-	4,5	3,9	4,4	3,9	42,0
44,0	-	-	-	-	-	-	-	-	-	3,6	3,9	3,5	44,0
46,0	-	-	-	-	-	-	-	-	-	3,4	3,5	3,1	46,0
48,0	-	-	-	-	-	-	-	-	-	-	3,1	2,7	48,0
50,0	-	-	-	-	-	-	-	-	-	-	2,7	2,3	50,0
52,0	-	-	-	-	-	-	-	-	-	-	-	2,0	52,0
54,0	-	-	-	-	-	-	-	-	-	-	-	1,7	54,0
56,0	-	-	-	-	-	-	-	-	-	-	-	1,5	56,0



12,9 - 60 m



7,5 m



360°



23,5 t



EN 13000

m	12,90°	12,90	17,69	22,48	27,16	31,84	36,45	41,24	45,99	50,71	55,39	60,00	m
2,2	119,0	-	-	-	-	-	-	-	-	-	-	-	2,2
3,0	94,5	92,0	86,0	81,0	65,0	-	-	-	-	-	-	-	3,0
4,0	81,0	77,5	76,5	71,0	65,0	50,0	-	-	-	-	-	-	4,0
5,0	70,5	66,0	66,5	63,5	60,5	49,5	38,0	-	-	-	-	-	5,0
6,0	62,0	57,5	57,5	57,0	54,5	47,0	37,0	28,0	-	-	-	-	6,0
7,0	55,0	50,0	50,5	50,5	49,5	44,0	35,0	28,0	20,5	16,0	-	-	7,0
8,0	48,0	44,5	45,0	45,0	41,5	40,5	33,0	28,0	20,5	16,0	11,6	-	8,0
9,0	39,5	39,0	39,5	38,5	36,5	34,5	31,5	26,5	20,5	16,0	11,6	10,0	9,0
10,0	31,5	31,5	34,5	33,0	32,5	30,0	29,5	25,0	20,5	16,0	11,6	10,0	10,0
11,0	-	-	29,5	28,5	28,5	26,5	26,5	23,5	20,5	16,0	11,6	10,0	11,0
12,0	-	-	25,5	25,5	25,5	24,5	23,5	22,0	19,5	16,0	11,6	10,0	12,0
13,0	-	-	22,5	22,5	22,5	23,0	21,5	19,9	18,6	16,0	11,6	10,0	13,0
14,0	-	-	20,0	20,0	19,8	20,5	19,3	18,0	17,3	15,8	11,6	10,0	14,0
15,0	-	-	-	17,8	18,0	18,5	17,5	16,7	15,7	15,2	11,6	10,0	15,0
16,0	-	-	-	16,6	16,9	16,6	16,0	16,0	14,3	14,1	11,6	10,0	16,0
18,0	-	-	-	13,8	14,0	13,6	13,3	13,7	12,0	11,8	11,6	10,0	18,0
20,0	-	-	-	-	11,7	11,4	12,0	11,5	10,7	10,0	10,1	9,7	20,0
22,0	-	-	-	-	9,9	9,6	10,2	9,7	9,9	8,5	8,9	8,9	22,0
24,0	-	-	-	-	6,2	8,2	8,8	8,2	8,6	7,8	8,3	7,7	24,0
26,0	-	-	-	-	-	7,0	7,6	7,0	7,4	7,3	7,3	6,7	26,0
28,0	-	-	-	-	-	6,0	6,6	6,0	6,3	6,6	6,3	5,8	28,0
30,0	-	-	-	-	-	-	5,7	5,2	5,5	5,7	5,4	5,0	30,0
32,0	-	-	-	-	-	-	5,2	4,5	5,1	5,0	4,7	4,3	32,0
34,0	-	-	-	-	-	-	-	4,2	4,6	4,4	4,0	3,6	34,0
36,0	-	-	-	-	-	-	-	3,9	4,0	3,8	3,5	3,1	36,0
38,0	-	-	-	-	-	-	-	-	3,6	3,3	3,0	2,6	38,0
40,0	-	-	-	-	-	-	-	-	3,1	2,8	2,5	2,1	40,0
42,0	-	-	-	-	-	-	-	-	2,7	2,4	2,1	1,7	42,0
44,0	-	-	-	-	-	-	-	-	-	2,1	1,8	1,4	44,0
46,0	-	-	-	-	-	-	-	-	-	1,8	1,4	1,0	46,0
48,0	-	-	-	-	-	-	-	-	-	-	1,2	-	48,0

* 0° over rear • nach hinten • en arrière • por la parte trasera • sul posteriore • Над задней частью

** 0° over rear with special equipment • Nach hinten mit Zusatzinrichtung • En arrière avec équipement supplémentaires • Por la parte trasera con equipo adicional • Sull'antieriore con equipaggiamento ausiliario • Над задней частью с специальным оборудованием